

# Some Parameters of Phonological Unmarkedness

Lee, Ki-suk \*

## Contents

- I. Introduction
- II. Parameters of Contrast in a Segmental Level
- III. Parameters of Contrast in Syllable Structure
- IV. Conclusion

## I. Introduction

Citing Fillmore's parable of a high-tech restaurant,<sup>1)</sup> Ohala and Kawasaki introduce two ways linguists attempt to solve problems of language structure and behavior: Formal approach and Substantive approach. As pointed out by them, in spite of the common aim of both approaches to attempt to uncover the realities of linguistic phenomena, the two still differ in that the former is concerned with purely formal accounts of some body of data whereas the latter aims to achieve a higher level of understanding and a greater capacity for prediction and generalization. Added to this is that it is often true that some purely formal analyses may be just no more than a clear description of what happens, but not an explanation of it. A good example in favor of the formal approach can be taken from a sequential if-then condition. English allows initial /p/, /b/, /k/, and /g/, but does not allow \*/t/ and \*/d/. In order to deal with this distinction, the formal approach will have to resort to the if-then condition which may be written as follows:

$$\begin{array}{l} (1) \text{ If} \quad : \#\# \left[ \begin{array}{c} -\text{cont} \\ C \end{array} \right] 1 \\ \quad \quad \quad \quad \quad \quad \quad \quad \downarrow \\ \text{Then} \quad : \quad \quad \quad \left[ -\text{cor} \right] \end{array}$$

\* Department of English, college of Humanities

1) See Ohala and Kawasaki (1984).

In prose, if a word-initial(##) noncontinuant is followed by /l/, then it must be either labial or velar, not alveolar. Note here that (1) doesn't provide any explanatory accounts of the above data in spite of its simple and elegant description. That is, in no way is (1) enough to give an answer to a 'why'-question with respect to the data in question. A very similar example of the sequential if-then condition can also be taken to indicate that English allows initial /tw/, /dw/, /kw/, and /gw/, but does not allow \*/bw/ and \*/pw/.

This time, the condition will have to be written as follows :

$$(2) \text{ If } \quad : \quad \begin{array}{c} \text{##} \\ \left[ \begin{array}{c} \text{-cont} \\ \text{C} \end{array} \right] \text{ w} \end{array}$$

$$\quad \quad \quad \Downarrow$$

$$\text{Then } : \quad \left\{ \begin{array}{l} [+cor] \\ [-ant] \end{array} \right\}$$

(2) says that if a word-initial (##) noncontinuant is followed by /w/, then it must be either alveolar or velar, not labial. Just as in (1), so in (2) the if-then condition fails to give an account of why it should be so.

A more serious difficulty with (1) and (2) above comes from a question of why they must be two independent conditions despite their striking similarity in both form and function. It might be supposed that their superficial difference can be merged as an underlyingly unifying condition if they are re-examined in terms of the substantive approach.

Turning to the substantive approach, the phonological motivation for both (1) and (2) seems to lie in contrast in the place of articulation. In (1) a process of noncontinuant C toward noncoronal is interpreted as the process of making the stop heterorganic to the following alveolar lateral. Exactly the same holds in (2), where a process of noncontinuant C toward either coronal or nonanterior is interpreted as the process of making the stop heterorganic to the following labio-velar semivowel. From this, it follows that the two word-initial segments can be contrasted to some extent in regards to their place of articulation. In a word, the two if-then conditions based on the formal approach can be unified as one principle of contrast in favor of the substantive approach. In what follows it will be demonstrated that some parameters of contrast play a pivotal role in answering some questions remained otherwise unsolved.

## II. Parameters of Contrast in a Segmental Level

First of all, let us begin our discussion by stating that the vowels /a/, /i/, /u/ are known as the basic three vowels<sup>2)</sup> since they are found in practically all languages<sup>3)</sup> and they are also the very first vowels learned by children. Notice, however, that these two reasons for the basic vowels are extremely superficial. They are not sufficient enough to provide any of what may be called an explanatory adequacy.

Unlike the two reasons given above, Schane (1973 : 10) refers to the perceptual contrast by pointing out that each of the basic three vowels is maximally opposed one from the other. More specifically, /a/ as a low vowel is opposed to /i/ and /u/ as high vowels. /i/ is maximally different from /u/ to the extent that the former is a high-pitched vowel as opposed to the latter which is a low-pitched vowel. Indeed, this idea of maximal difference in vowel inventories seems to be the very source of the two superficial reasons mentioned above. That is, it may be possible to say that really all languages have at least the basic three vowels in common since they are the maximally different vowels. It may also be possible to say that children learn first these three vowels rather than the other vowels<sup>4)</sup> since they are maximally different, articulatorily or acoustically. From this perspective, it may be assumed that the maximally different vowels are unmarked while the minimally different vowels are marked. This assumption in turn leads to the claim that the vowels /a/, /i/, /u/ are the unmarked vowels and the other vowels are, to some extent, marked vowels, depending on how much they differ.

The same holds in our discussion of consonant inventories. The consonants /p/, /t/, /k/ are assumed to be the most basic three consonants for the same reasons given for the argument of the basic three vowels. As pointed out by Jakobson and many other

---

2) This idea is supported by the fact that such languages as Eskimo and some Arabic dialects have only these three vowel phonemes. Note further that Russian syllables are unstressed only in these three vowels. Following the concept of Trubetzkoy's privative opposition, the unstressed syllables are assumed to be unmarked whereas the stressed syllables are assumed to be marked. If this is the case, then it follows that the vowels /a/, /i/, /u/ are the basic vowels in Russian since they are most unmarked in regards to the assignment of stress.

3) By the phrase 'practically all languages', we mean here that the /i/ and the /u/ are extremely common in languages, but are not universals. Only /a/ is the true linguistic universal.

4) This is due to Jakobson.



|               |     |               |
|---------------|-----|---------------|
| b. Stops      | vs. | Fricatives    |
| [-sonorant]   |     | [-sonorant]   |
| [-continuant] |     | [+continuant] |
|               |     |               |
| c. V1 Stops   | vs. | Vd Stops      |
| [-sonorant]   |     | [-sonorant]   |
| [-continuant] |     | [+continuant] |
| [-voiced]     |     | [+voiced]     |

As can be seen in (4), obstruents are represented by just one parameter of contrast—sonorant—in favor of unmarkedness; stops by two parameters of contrast—sonorant and continuant—in favor of unmarkedness; and finally voiceless stops by three parameters of contrast—sonorant, continuant and voiced—in favor of unmarkedness. Given this analysis, voiceless stops are the most unmarked consonants since they are represented by more parameters of contrast in favor of unmarkedness than the other consonants are.

Notice here that the implicational law is a clear clue to the claim that voiceless stops are unmarked. It is assumed that when X implies Y but Y does not imply X it is X that is characterized by [+F] and Y by [-F]. Such being the case, it is possible to say that in (4a) sonorants imply obstruents but the reverse does not hold true; in (4b) fricatives imply stops but stops do not imply fricatives; in (4c) it is the voiced stops that imply the voiceless stops. In relation to (4c), to put it more specifically, a series /b,d,g/ implies a series /p,t,k/, but the reverse is not the case. On the basis of this observation, it may be assumed that languages with /p,t,k,b,d,g/ and languages with /p,t,k/ are possible languages whereas languages with /b,d,g/ and languages with no stops are not possible languages.

Another point to be noted with regard to the implicational law is that if X implies Y but Y does not imply X then X and Y are neutralized as Y. In other words, it is unmarked Y rather than marked X that is found in the position of neutralization. A typical example is taken from Standard German. There is a voicing contrast in German between the voiceless consonants /p,t,k,f,s/ and the voiced consonants /b,d,g,v,z/. This contrast remains in syllable-initial position, but it is neutralized as the unmarked voiceless consonants in syllable-final position. Compare the word pair of Tier [ti:r] 'animal' and dir [di:r] 'to you' with the word pair of Rat [ra:t] 'advice' and Rad [ra:t] 'wheel'.

Not only in German but in English do the most unmarked voiceless stops survive a neutralizable opposition. In English the voiceless stops /p,t,k/ come after the word-initial /s/, as opposed to the voiced stops /b,d,g/ which are not preceded by /s/. Hence the

contrast between the permissible word-initial clusters *sp*, *st*, *sk* and the impermissible word-initial clusters, *\*sb*, *\*sd*, *\*sg*.

So far, we have shown that voiceless obstruents stand in sharp contrast to voiced obstruents to the extent that the former is unmarked and the latter is marked. Whether in English or in German, voiceless obstruents and voiced obstruents are neutralized as voiceless obstruents.

Now let us examine how the acoustic feature operates with regard to the parameter of contrast. Consider the following two groups of words, from Ladefoged(1982).

- |        |           |   |    |    |           |   |    |
|--------|-----------|---|----|----|-----------|---|----|
| (5) a. | cliff [f] | } | +s | b. | kiss [s]  | } | +s |
|        | moth [θ]  |   |    |    | dish [ʃ]  |   |    |
|        | dove [v]  |   |    |    | maze [z]  |   |    |
|        | lathe [ð] |   |    |    | rouge [ʒ] |   |    |

In (5a), plural forms of the words are made with the addition of a plural suffix phonetically realized as an alveolar fricative [s] or [z], depending on the presence or absence of the voicing of the word-final segment. In (5b), on the other hand, the plural suffix can not directly be added to the end of the words. In this case, an epenthetic vowel is inserted to break up the successive two segments only if the final consonant of the words is either alveolar or palato-alveolar but not dental as in the case of (5a). Keeping this in mind, it is possible to make the following rule based on the articulatory position.

$$(6) \quad \phi \rightarrow V / \left\{ \begin{array}{l} \left[ \begin{array}{l} \text{fricative} \\ \text{alveolar} \end{array} \right] \\ \left[ \begin{array}{l} \text{fricative} \\ \text{palato-alveolar} \end{array} \right] \end{array} \right\} \text{ --- } + \left[ \begin{array}{l} \text{fricative} \\ \text{alveolar} \end{array} \right]$$

What (6) indicates with regard to the formation of plural forms is that words ending in alveolar fricatives behave like those ending in palato-alveolar fricatives, but differently from those ending in dental fricatives. But what (6) crucially lacks is the reason why alveolar fricatives and palato-alveolar fricatives act together in the application of (6). In other words, the question of why a series of *-θs* and *-ðz*, for example, are permissible and a series of *-ʃs* and *-ʒz* are not permissible can not be answered with any reference to

the articulatory contrast.

If we resort to the acoustic parameter of contrast, however, it is explicitly accounted for. The key to the parameter here is sibilant. Alveolar fricatives and palato-alveolar fricatives fall into sibilant acoustically. On the contrary, labio-dental fricatives and dental fricatives fall into non-sibilant. Therefore, it follows that in (5a) the two successive fricatives for plural forms consist of [-sibilant] and [+sibilant] while in (5b) they consist of [+sibilant] and [+sibilant]. Hence acoustic unmarkedness in (5a) vs. acoustic markedness in (5b). Following this acoustic parameter of contrast, the rule (6) with no motivation should be replaced by the acoustically motivated rule in which epenthesis occurs to make unmarked the marked succession of sibilants in the formation of plural forms.

Now let us turn to the discussion of phonotactics. As we remarked earlier, the parameter of contrast illustrated by the sequential if-then condition gives an answer to some of the phonotactic questions. For the sake of further discussion, consider the following.

|            |         |        |
|------------|---------|--------|
| (7) a. pr- | b. *pw- | c. pl- |
| br-        | *bw-    | bl-    |
| tr-        | tw-     | *tl-   |
| dr-        | dw-     | *dl-   |
| kr-        | kw-     | kl-    |
| gr-        | gw-     | gl-    |

In (7) the only impermissible consonant clusters in word-initial position are \*pw, \*bw, and \*tl, \*dl. What they have in common is that their two word-initial consonants are all homorganic. More specifically, in (7b) bilabial /p/ and /b/ are followed by another bilabial /w/. Thus, there is no contrast with regard to the place of articulation. The same holds in (7c) since alveolar /t/ and /d/ are followed by another alveolar /l/. Since the impermissibility of consonant clusters in (7) stems from the impermissibility of the homorganic consonant clusters resulting in no contrast, it seems to give rise to a universal constraint on impermissible duplication of any two identical segments: \*tt, \*pp, \*kk, \*aa, \*ii, and \*uu, to take a few examples.

What should be noted in (7b) in particular is the fact that \*pw and \*bw are impermissible while kw and gw are not. If we say that \*pw and \*bw are not permissible since the bilabial /p/ or /b/ is followed by another bilabial /w/, then we can expect to say that kw and gw should also be impermissible since the velar /k/ or /g/ is followed by another velar /w/. Note here that /w/ is a labio-velar semivowel. The position of the

starting point of /w/ may be characterized as follows :

- (8) a. The lips are closely rounded.  
 b. There is a considerable raising of the back of the tongue in the direction of the soft palate.  
 c. The vocal cords are made to vibrate so that voice is heard.

The /w/ is both bilabial and velar because of the above (8a) and (8b). Note, however, that the two places of articulation in question do not always work in all contexts. When the /w/ is preceded by stop sounds it acts to take part in an anticipatory coarticulation with the lips pursed up to about the same degree as for the English high back vowel. On the other hand, (8b) does not operate in this situation. The role of (8b) is replaced by each place of articulation for the preceding stop sounds. Assuming this observation and assuming that the lip-rounding of (8a) is realized as bilabial, we can compare the cases in (7) as follows :<sup>6)</sup>

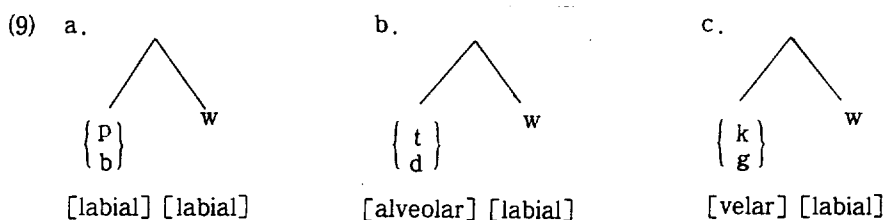

As shown in (9), (9b) and (9c) differ from (9a) in that only in the latter lack the two word-initial segments the contrast in the place of articulation. To put it another way, in (9a) the two segments are homorganic while such is not the case in (9b) and (9c). Hence the impermissibility of (9a) by dint of the lack of contrast. One thing to be further added is that the words beginning with (9c) are by far the more frequent than those beginning with (9b), particularly when the first consonant is voiceless. Following the way of our discussion so far, this observation will have to be based on the assumption that (9c) is more unmarked than (9b) in the sense of contrast in their two segments. In order to see what happens in (9b) and (9c) with regard to contrast, let us resort to Chomsky and

6) The branch in (9) is used to indicate that the two successive segments form a node Onset in the syllable structure.



Halle's feature anterior. Then (9b) and (9c) would be :

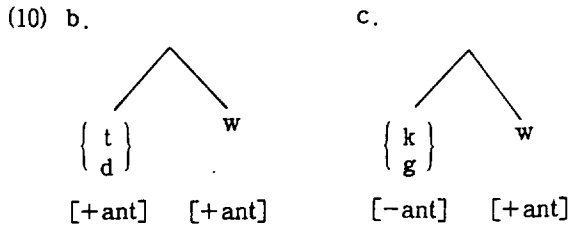

As can be seen in (10), (10b) is the case in which the two segments in word-initial position consist of the identical values of the feature [ant]. By contrast, the two initial segments in (10c) consist of different values of the same feature. It is, therefore, expected that (10c) is more unmarked than (10b), and *kw*, for example, is more frequent than *tw* in that position. In addition, it is also the case that out of (10b) and (10c), *tw* is more frequent than its counterpart *dw* and *kw* than *gw*, respectively. Since /w/ is voiced, as pointed out in (8c), it will be more unmarked when it is preceded by the voiceless segment rather than the voiced segment. Taken together, on the basis of what we have observed so far, the four possible word-initial clusters in question would be distinguished by the following (11).

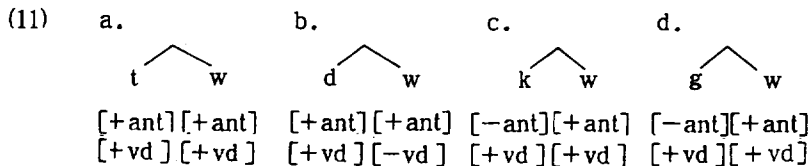

The distinction in (11) is made with the two parameters [ant] and [vd], together with the two values plus and minus. The parameters of different values in each case play a crucial role in creating contrast. Such a parameter will be named "Crucial Parameter" (henceforth CP) for our discussion. Then we can say that there is only one CP, [vd] in (11a); no CP in (11b). The difference in the number of CP between the two cases gives rise to the difference in unmarkedness, which in turn gives rise to the difference in frequency. Looking now at the difference between (11c) and (11d), there are two CP's in (11c) while there is only one CP in (11d). Thus, we can simply say that (11c) is more unmarked than (11d). Given this, it is also the case that (11c) is more

unmarked than (11a) because of the difference between them in the number of CP. One thing that still remains an open question, however, is the comparison in frequency between (11a) and (11d), both of which have only one CP in common even though they have different CP's. At this point of our discussion, it seems to be worth noting that there should be a third CP that can account for the difference between them if it is really the case that there is any difference in markedness. Notice here that together with [ant], [cor] can also be an inventory for CP. With [cor] as a CP added to (11a) and (11d), they may be modified as follows :

(11) (modified)

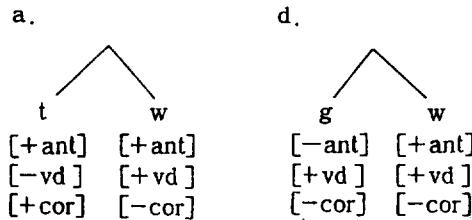

Given (11) (modified), it is clear that (11a) is more unmarked than (11d). Taken together, we can say that (11c) is the most unmarked word-initial cluster, and then comes (11a), which is followed by (11d) and (11b) in that order. Note here that this order of unmarkedness is marvelously attested by the frequency of words beginning with the four possible consonant clusters. Consider the following data about frequency from a dictionary.

(12)

|     | initial cluster | number of words |
|-----|-----------------|-----------------|
| 11c | kw-             | thousands       |
| 11a | tw-             | more than 100   |
| 11d | ɣw-             | about 20        |
| 11b | dw-             | about 10        |

Turning to (7), in a word, the impermissibility of \*pw, \*bw and \*tl, \*dl is due to their homorganic situation. But notice that in such phenomena as the nasal plosion and the lateral plosion the homorganic situation is permissible. The nasal plosion occurs when an alveolar stop /t/ or /d/ is followed by alveolar nasal /n/ in word-final position. As far as homorganic situations are concerned, the nasal plosion must be impermissible just as the homorganic \*bw or \*pw is impermissible. Exactly the same is true for the lateral plosion in which the alveolar stops /t/ or /d/ are followed by a lateral in word-final position. Then the question arises as to what makes the behavior of a nasal plosion or lateral plosion different from the behavior of \*bw or \*pw. Unlike the case of \*bw or \*pw, the plosion, nasal or lateral, though it occurs in a homorganic situation, seems to refer to the contrast of the presence or absence of the explodedness between the two word-final segments. Whether in a nasal plosion or in a lateral plosion, it is the case that the alveolar stops /t/ or /d/ are unexploded as opposed to the following /n/ or /l/, which are exploded. That is, it is explodedness that plays a role of CP in these two phenomena. Now consider the following examples of nasal plosion and lateral plosion.

- |                      |                 |
|----------------------|-----------------|
| (13) a. sudden [-dn] | b. little [-tl] |
| sadden [-dn]         | ladle [-dl]     |
| leaden [-dn]         | middle [-dl]    |
| mutton [-tn]         | cattle [-tl]    |
| kitten [-tn]         | medal [-dl]     |

The examples in (13a) indicate nasal plosion and those in (13b) lateral plosion. Since the two phenomena are not independent, the environment in which they can occur may simply be written as :

$$(14) \quad v \left\{ \begin{array}{c} t \\ d \end{array} \right\} \left\{ \begin{array}{c} n \\ l \end{array} \right\} \#$$

In (14), the CP is [exploded] in the sense that the penultimate segment has the -value of [exploded] and the final segment has the +value of [exploded]. It is worth noting here that another CP is applicable to (14). That is [syllabic]. As can be seen in (14), the penultimate segment is [-syllabic] while the final segment is [+syllabic].

So far, we have shown that in the case of word-final consonant clusters, the two homorganic segments of both nasal plosions and lateral plosions are permissible since their CP's contrast in the [exploded] and [syllabic] domains. But there are no such CP's in word-initial consonant clusters. That is why neither nasal plosion nor lateral plosion occurs in word-initial position. That is, we have no word-initial counterpart of (14), as will be illustrated in (15) below.

$$(15) \text{ *}\# \left\{ \begin{array}{c} t \\ d \end{array} \right\} \left\{ \begin{array}{c} n \\ l \end{array} \right\} V$$

Unlike the case of (14), in (15) the alveolar stop /t/ or /d/ is assumed to be exploded since it is in word-initial position. It is also assumed to be unexploded when preceding a nasal or lateral just as in the case of the penultimate segment of a word-final cluster. But no segment can be both exploded and unexploded at the same time. Thus, (15) is not permissible. Added to this is the fact that in (15) there is no contrast in the CP of [syllabic] since both segments are [-syllabic]. Hence, there is no plosion, nasal or lateral, in word-initial position.

A similar comparison can also be made as in (16) below.

$$(16) \text{ a. } V \left\{ \begin{array}{c} p \\ k \end{array} \right\} t \# \quad \text{ *}\# \left\{ \begin{array}{c} p \\ k \end{array} \right\} t V$$

In both cases of (16) the consonant clusters consist of stop sounds. The only difference between (16a) and (16b) is that the former is the case of word-final clusters and the latter is the case of word-initial clusters. What causes the difference in permissibility is the contrast in the CP of [exploded] in (16a), but not in (16b). In (16a) the penultimate stop is unexploded while the final stop is exploded. Such is not the case in (16b). Hence permissible (16a) vs. impermissible (16b). To take a few examples of (16a), we have such words as *act* [æk<sup>◦</sup>t] and *apt* [æp<sup>◦</sup>t], where a small raised circle is used for the narrow transcription.

### III. Parameters of Contrast in Syllable Structure

In the previous section we have chiefly dealt with some phonological characteristics of segments on the basis of the notion of contrast. In this section, however, our main concern will be placed on the contrast in the structure of the syllable. Following the proposals of a number of phonologists, it is suggested that a syllable structure for English can be organized hierarchically into Onset and Rhyme, which is in turn organized into Nucleus and Coda. Given this, it is clearly the case that a sequence of the sort CVC, for example, has a structure of two levels of binary branching rather than a structure of one level of single ternary branching. This analysis makes it possible to propose the following structure.

(17)

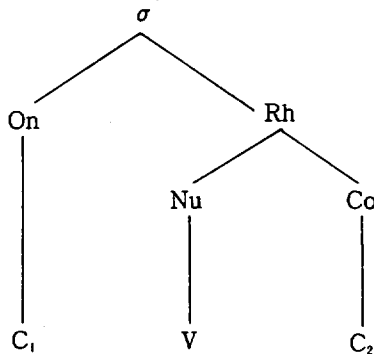

Following again the proposals of many leading phonologists, it is also suggested that each of the terminal nodes in (17) can be maximally composed of two segments in the normal structure for an English stressed syllable. According to this proposal, (17) can be maximally extended as can be seen in (18) below.

(18)

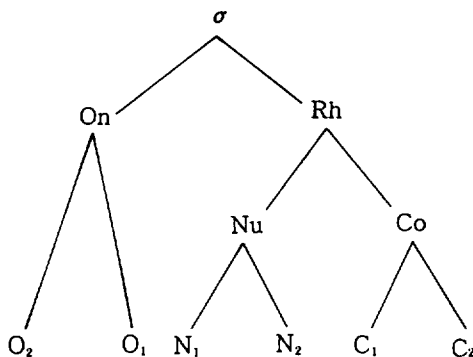

In our discussion of contrast in syllable structure, special attention will be given to the phonotactic relationship between  $O_2$  and  $O_1$  in (18). The reason why Onset is selected here is not because Nucleus and Coda are not worth being discussed, but because the phonotactic relation between the two elements in Onset is more stringent than that in the Nucleus or Coda. As to what should be done in Onset, Hogg and McCully (1987 : 43) propose their brilliant Onset Template Condition (Henceforth OTC), which will be cited as follows :

- (19) Onset Template Condition (OTC)
- a.  $O_1$  is optionally filled.
  - b.  $O_2$  is filled iff  $O_1$  is filled.
  - c. Sonority Value (SV) of  $O_1 \leq 8$ .
  - d. (SV) of  $O_1 \geq 6$  iff  $O_2$  is filled.
  - e. SV of  $O_2 \leq 3$ .

Indeed this condition gives a good guide to the distinction between the permissible words such as *true*, *glue*, *blue*, *threw*, *twin*, *swim* etc. and the impermissible words such as \*vrue, \*nrue, \*zwin, \*nwin, \*gvin etc. The sonority value of the two syllable-initial consonants for each word above can be given :<sup>7)</sup> 1-7 for *true*, 2-6 for *glue*, 3-6 for *flue*, 3-7 for *threw*,] 1-8 for *twin*, and 3-8 for *swim*, but 4-7 for \*vrue, 5-7 for \*nrue, 4-8 for \*zwin, 5-8 for \*nwin, finally 2-3 for \*gvin. In a word, the permissible words meet (19d) and (19e) while the impermissible words do not meet them. As such, the above OTC is in no way deficient in describing the possible and/or impossible consonant clusters in syllable-initial position.

Note, however, that the OTC fails to provide any explanation, for example, of why the demarcation line in the SV of  $O_2$  should be drawn between 3 and 4. Never is the OTC based on any empirical evidence for the critical distinction between SV 3 and SV 4. Note here that it seems to be possible to have access to the empirical evidence by defining the linguistically significant difference between them. The sonority value 3 is represented as voiceless fricatives and the sonority value 4 is represented as voiced fricatives. Then a question arises as to why it is that  $O_2$  should be filled with voiceless fricatives, but not with voiced fricatives. Remember here that in the previous section we pointed out that no two identical segments, consonants or vowels, are phonotactically permissible, since that

7) See Hogg & McCully (1987) for the sonority value.

is the case in which there is no contrast between them articulatorily or perceptually. Keeping this in mind, it might also be possible to say that in the position of Onset, no two segments have an identical sonorant value. Therefore, the following structures of Onset are not permitted due to the lack of contrast in their sonorant parameter.

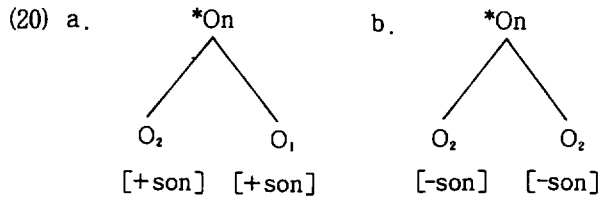

Given (20) above, such impermissible words as \*nrue and \*nwin can simply be accounted for. Whether in (20a) or (20b), there is no CP of [sonorant] in relation to contrast. In order to show any contrast in [sonorant], therefore, the two members of Onset, O<sub>2</sub> and O<sub>1</sub> should have a different sonorant value, in one way or another. Consider then the following two cases in which there seems to exist a contrast in [sonorant] between O<sub>2</sub> and O<sub>1</sub>.

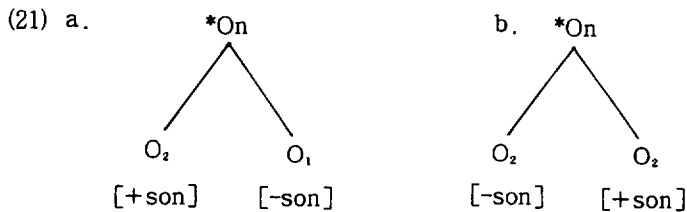

Despite the difference in the value of sonorant, it should be noted that (21a) is ruled out by Selkirk's Sonority Sequencing Generalization (henceforth SSG), which states :

- (22) In any syllable, there is a segment constituting a sonority peak that is preceded and/or followed by a sequence of segments with progressively decreasing sonority values.

Taken together, (21b) is the only possible structure of Onset that can not be at variance with both SSG and CP of sonorant. Note, however, that (21b) is not always permissible. As mentioned in the previous section, [-son] falls into [+continuant] and [-continuant], both of which in turn fall into [+voiced] and [-voiced]. On the basis of this

sort of classification, the  $O_2$  of (21b) might be modified to add two more parameters for contrast. Now look at the following.

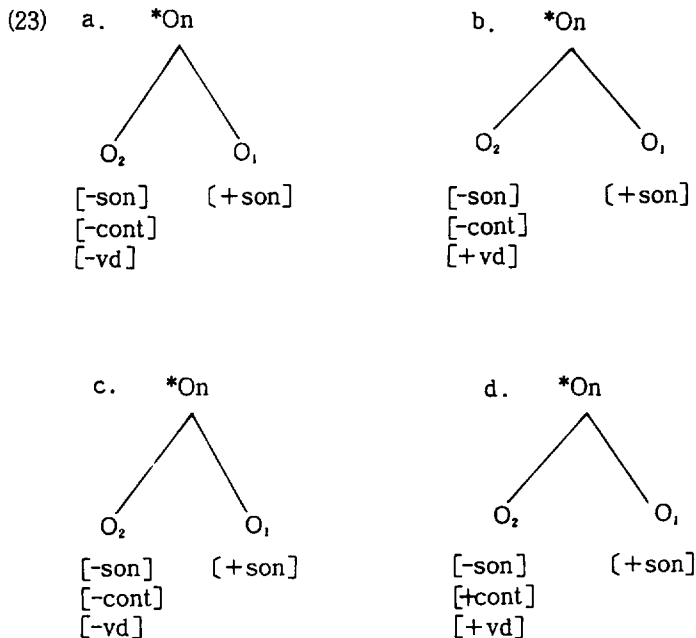

(23a) is the case in which  $O_2$  is filled with voiceless stops; (23b) with voiced stops; (23c) with voiceless fricatives and finally (23d) with voiced fricatives. In (23a) and (23b) it is supposed that when  $O_2$  is filled with stop sounds, voiceless or voiced, the contrast between  $O_2$  and  $O_1$  is enough to create a permissible Onset structure. But the situation is different in (23c) and (23d), where  $O_2$  is filled with fricative sounds.

The only difference between (23c) and (23d) is in the presence or absence of voicing. In (23c) the absence of voicing seems to play the role of forming a contrast in sonority between  $O_2$  and  $O_1$ . On the other hand, in (23d) it is the presence of voicing that fails to form enough of a contrast between  $O_2$  and  $O_1$ ; thus,  $O_2$  and  $O_1$  are not given a permissible Onset structure. Following the concept of Trubetzkoy's privative opposition again, which states that the -value is the unmarked value while the +value is the marked value, it is the case that the  $O_2$  of (23a) is most unmarked with no +value; the  $O_2$  of (23b) and (23c) is in-between with one +value; the  $O_2$  of (23d) is least unmarked with two +values. Given this analysis, *prima facie* (23c) can naturally be paired with (23b) rather than (23d). In order to scrutinize the degree of unmarkedness in detail, suppose



that we assign the value 3 to the parameter of sonorant, 2 to the parameter of continuant, and 1 to the parameter of voicing. Then the sum of the number given to each  $O_2$  of (23a)-(23d) is as follows.

|            |         |         |         |
|------------|---------|---------|---------|
| (24) a. On | b. Or   | c. On   | d. *On  |
|            |         |         |         |
| $O_2$      | $O_2$   | $O_2$   | $O_2$   |
| [-son]     | [-son]  | [-son]  | [-son]  |
| [-cont]    | [-cont] | [+cont] | [+cont] |
| [-vd]      | [+vd]   | [-vd]   | [+vd]   |
| -6         | -4      | -2      | 0       |

As illustrated by the negative number, (24a), (24b) and (24c) indicate varying degrees of contrast. In addition, it is further supposed that the degree of contrast is determined by the difference in number given above: (24a) > (24b) > (24c), where > means 'is greater than'. On the other hand, the number zero given to (24d) can be interpreted to mean that the voiced fricative in  $O_2$  can not be contrasted.

Such being the case, it is possible to say that such words as *twin* and *true* are permissible because of (24a); the word *glue* because of (24b); such words as *flue*, *threw* and *swim* because of (24c), but that \**zwin* and \**vrue* can not be permissible because of (24d). Another thing to be said with regard to (24) is that the degree of unmarkedness based on the assigned numerical difference is closely related to the frequency of words beginning with each Onset structure of (24). This is proved by the fact that in English the words beginning with, for example, /tr/ occur more frequently than those beginning with /dr/, which is followed by those beginning with /θr/. Added to this is the fact that (24) provides a criterion for making it possible to divide four possible Onset structures up into two linguistically significant groups: one includes (24a)-(24c) represented as -number and the other is (24d) not represented as -number. In other words, this observation is in itself an answer to the question of why SV 3 in the sense of Hogg and McCully should be a maximal number for  $O_2$ . Notice here that our observation based on (24) may be critically supported by Ladefoged's 'relative sonority of English sounds' (1982: 222), which is graphically schematized as (25) with the exception to the sonority of vowels.

(25)

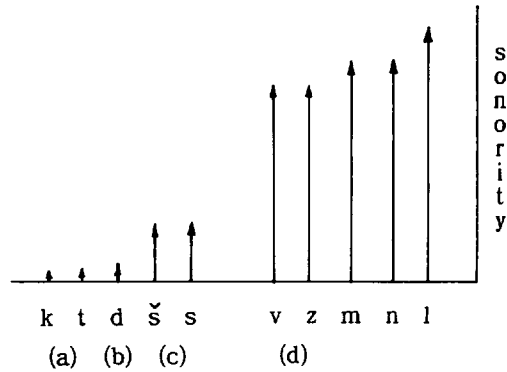

As pointed out in our discussion of (24), here the sharp contrast between (25c) and (25d) shows that (25a)-(25c) can form one and the same group to the exclusion of (25d). Up to this point, we have presented the view that the relationship between  $O_2$  and  $O_1$  should be based not on the purely formal number system but on the empirical concept of contrast according to which the voiceless fricative equivalent to (24c) or (25c) is the maximal candidate for  $O_2$  position.

Now consider the case of the CV syllable in which C can be realized as one of four possible consonant classes: O, N, L, and G, where O=Obstruents, N=Nasals, L=Liquids and G=Glides. Therefore, it follows that the four possible classes of CV syllables are OV, NV, LV and GV. As pointed out by Hooper (1976: 196), OV is the most optimal syllable and GV is the least optimal syllable, and NV and GV are in-between, in that order. Following this, her observation can graphically be represented as follows:

(26)

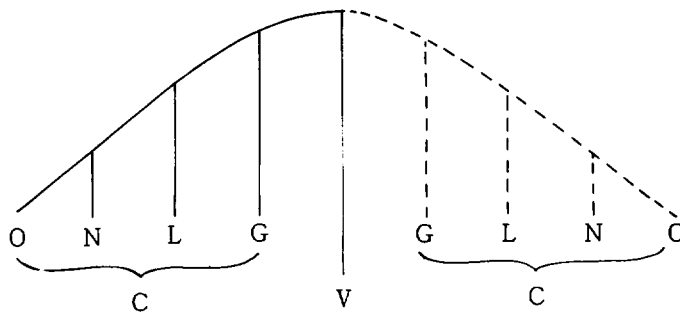

Note that the dotted part on the right in (26) will not be discussed here since it is part of the Coda, which is not our concern at the moment. In the part on the left, it is supposed that Hooper's view on the optimal syllable-initial corresponds to the degree of unmarkedness in terms of contrast in sonority between C and V. More specifically, for example, the OV syllable is the most optimal syllable since it is most unmarked with regard to contrast and the GV syllable is the least optimal syllable since it is least unmarked. On the basis of this observation, it seems to be valid to assert that of the four possible groups of syllables such as (i) *pa, ta, ka* (ii) *ma, na* (iii) *la, ra* (iv) *ya, wa*, children will learn (i) first and then (ii), which is followed by (iii), and finally (iv). Related to this is the question as to which one of the two members of Onset is more deletable. It is  $O_1$  that is deleted. For example, in a syllable structure of  $C_2C_1V$  there is a tendency to delete  $C_1$  rather than  $C_2$  in a context in which we have to delete one of the two consonants. This tendency is easily accounted for since it is the case that  $C_1$  has a higher value of sonority than  $C_2$  and that  $C_2V$ , as a result of deleting  $C_1$ , is more unmarked than  $C_1V$  as a result of deleting  $C_2$  in the sense of (26). Let us introduce here an experimental instance. The word *ice cream* was found to be pronounced [ha-kim] and [aŋ-kim], respectively by my two children. Aside from the first syllable differently pronounced, what we are going to be concerned with is that they had the second syllable in common with the deletion of the second consonant /r/, but not with the deletion of the first consonant /k/. Hence *kim* instead of *rim*. The question of why it is the case can be answered when we take into account the difference in unmarkedness between /ki/ of *kim* and /ri/ of *rim*. Following the sense of (26), the vowel /i/ in question is more unmarkedly preceded by /k/ than it is preceded by /r/.

Now let us turn to the discussion that the CV syllable is the most unmarked syllable. As pointed out by a lot of phonologists, the CV syllable is really universal in that there is no language that does not allow that syllable type and that it is the first syllable type learned by children. In relation to this view, note first that Clements and Keyser (1983 : 28) propose that there is a primary set of four syllable types : (i) CV (ii) V (iii) CVC and (iv) VC. Of the four types of syllable they point out that type (i)—the CV type—is the most unmarked type and type (iv)—the VC type—is the most marked type. But no substantive evidence is given to prove that the CV syllable is most unmarked as opposed to the VC, which is most marked. Remember at this point that we proposed the syllable structure of English in (17), repeated here for the sake of our discussion.

(17)

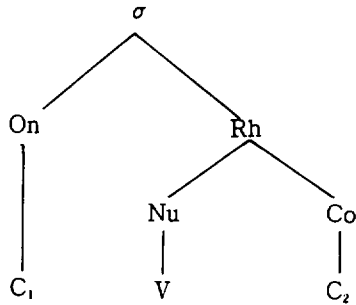

As can be seen in (17), it is clear that  $C_1$  (i.e. the C in the position of Onset) is structurally different from  $C_2$  (i.e. the C in the position of Coda). The  $C_1$  is immediately dominated by  $\sigma$  whereas the  $C_2$  is not. On the other hand, the  $C_1$  c-commands both V and  $C_2$ , but neither V nor  $C_2$  c-commands  $C_1$ . On the basis of this difference between  $C_1$  and  $C_2$  in (17), we assume that a consonant is unmarked when it is immediately dominated by  $\sigma$ , while it is marked when it is not immediately dominated by  $\sigma$ . Consider then the following syllable structures of CV type and VC type, respectively.

(27) a.

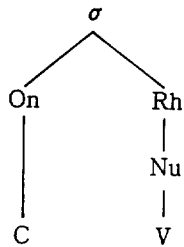

b.

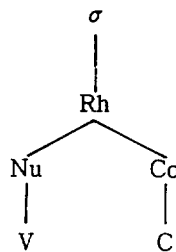

In (27a), the C is immediately dominated by  $\sigma$  and the branching occurs in the node  $\sigma$ . By contrast, in (27b) the C is not immediately dominated by  $\sigma$  and the branching occurs in the node Rh. This structural contrast seems to lead one to assume that the higher the branching node, the more unmarked the syllable is. We assume further that just as the C is unmarked when it is immediately dominated by  $\sigma$ , the V is also unmarked when it is immediately dominated by  $\sigma$ . On the face of it, there seems to be no case in which the V is immediately dominated by  $\sigma$  since the V is always a daughter node of Rh. Following a convention of tree pruning in the sense of Ross (1966d), however, even the V can be immediately dominated by  $\sigma$  when the Rh does not branch. Tree pruning is necessary for

the syllable structure of type (ii). The following is given to show how tree pruning operates to meet our assumption.

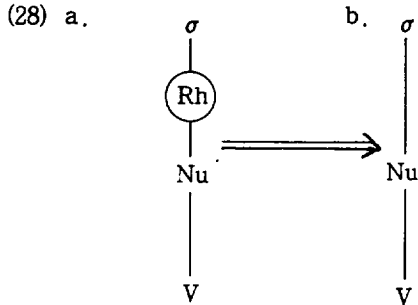

In (28a), the circled Rh should be erased by tree pruning since it does not branch. Thus the application of tree pruning results in (28b), in which the terminal node Nu is immediately dominated by  $\sigma$ . Note further that this tree pruning should also be applied to (27a), where the Rh does not branch. If this is the case, then (27a) should be modified as the following structure.

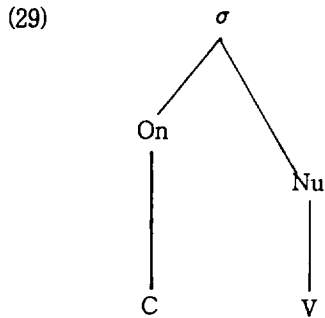

Now that we have readjusted the syllable structure in terms of tree pruning, it seems to be possible to discuss the degree of unmarkedness for the four core syllable types proposed by Cements and Keyser. For the sake of convenience their four core syllable types will be repeated here as (30).

- (30) a. CV  
b. V

- c. CVC
- d. VC

As pointed out by them, (30a) is the most unmarked, while (30d) is the most marked. Another proposal offered by them is that (30a) is universal and it is the very source of the other three types, which are yielded by their two operations given below as :

- (31) a. delete syllable initial C
- b. insert syllable final C

Given (31), it follows that (30b) is derived by the application of (31a); (30c) by the application of (31b); and finally (30d) by the application of both (31a) and (31b). Following their argument, there seems to be no plausible criterion for determining the degree of unmarkedness between (30b) and (30c). In fact, there is no empirical evidence to show that the syllable structure derived by (31a) is more unmarked than that derived by (31b). Following our assumptions given above, however, it will be shown that the degree of unmarkedness is determined in the order given in (30). Now then let us have a close look at the structures of four syllable types in question.

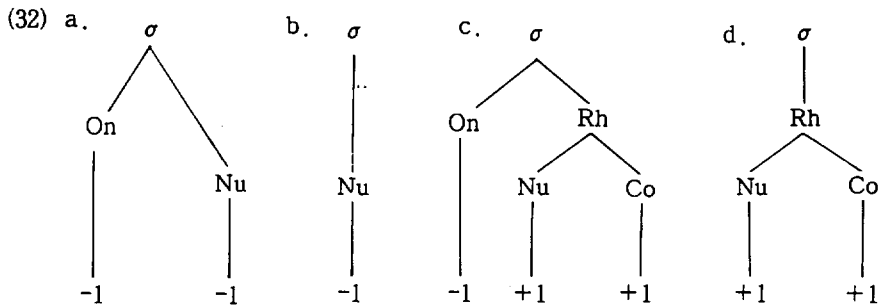

In (32a), both On and Nu are immediately dominated by  $\sigma$ , since the node Rh which immediately dominates Nu is erased by tree pruning. For the same reason, in (32b) only the node Nu is immediately dominated by  $\sigma$ . Next is (32c), where though the On is immediately dominated by  $\sigma$  there remain two nodes not immediately dominated by  $\sigma$ . Then comes (32d), in which there is no node immediately dominated by  $\sigma$ . Given this observation, let us suppose that we assign the value -1 to the node immediately dominated by  $\sigma$  and the value +1 to the node not immediately dominated by  $\sigma$ . Then the sum of the

number assigned to each of (32) will be as follows: -2 to (32a), -1 to (32b), +1 to (32c) and +2 to (32d).

Thus far, on the basis of the structural contrast of the syllable types, we have unequivocally demonstrated that the degree of unmarkedness in the four core syllable types is CV > V > CVC > VC in that order, where > means 'is more unmarked than'. Let us then turn to the discussion of the Onset First Principle. Note, first, that in his dissertation Kahn (1976) proposed his elegant Rule II, which states:

(33) [=Kahn's Rule II]

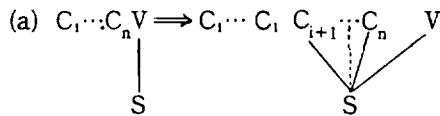

where  $C_{i+1} \dots C_n$  is a permissible initial cluster  
but  $C_1 C_{i+1} \dots C_n$  is not.

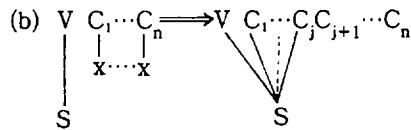

where  $C_1 \dots C_j$  is a permissible final cluster  
but  $C_1 \dots C_j C_{j+1}$  is not.

In relation to (33) [=Kahn's Rule II a,b], Kahn assumes the ordering (a) followed by (b). Consider, for example, the following process of syllabification of the words *mist* and *Boston*.

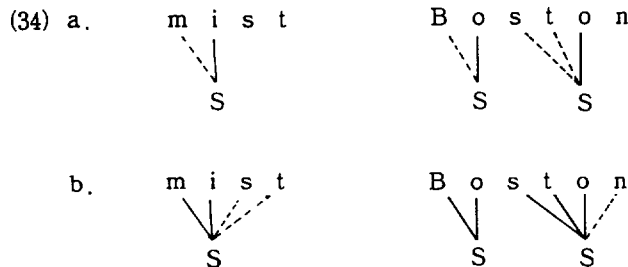

As can be seen in (34b), Rule II b applies to the post-vocalic [st] of *mist* but not the

post-vocalic [st] of *Boston*. As pointed out by Kahn himself, this is a consequence of the fact that only in *mist* is [st] not assigned a syllabic association by Rule II a. The medial [st] of *Boston* can not be assigned a syllabic association by Rule II b, since it has already been associated with the second syllable by rule II a. On the basis of this observation, Kahn concludes that in the slow speech there is a tendency toward maximal initial clusters rather than maximal final clusters. That is, Kahn's assumption leads one to conclude that the syllable division of *Boston* is [Bo-ston] but not [Bost-on]. Note, however, that he does not give an answer to the question of why the syllable division [Bost-on] is not permissible. In other words, his conclusion about the Onset First Principle is not based on the serious question of what's wrong with the rule ordering II b followed by II a.

Now then consider our assumptions based on the structural contrast of syllable types in determining the degree of unmarkedness. The two possible syllable structures of *Boston* will be (35), depending on the Principle of Maximal Coda or the Principle of Maximal Onset.

(35) a.

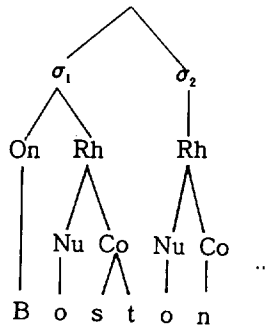

b.

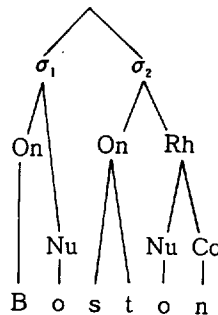

Roughly, the  $\sigma_1$  of (35a) is equal to the  $\sigma_2$  of (35b) in the degree of unmarkedness since both are the syllable of the type CVC. The crucial difference in the degree of unmarkedness is between the  $\sigma_2$  of (35a) and the  $\sigma_1$  of (35b). Since there is no Onset in the  $\sigma_2$  of (35a), the Nu and Co may be assigned the value +1, respectively, following the way assumed in (32). On the other hand, in the  $\sigma_1$  of (35b) the On and Nu may be assigned the value -1, respectively, since both are immediately dominated by  $\sigma_1$ . Now compare the  $\sigma_1$  of (35a) with the counterpart of (35b). If the structures of (35a) and (35b) are really the case, then the number of unmarkedness would be given +1 to the former and -2 to the latter. On the basis of this, it follows that the first syllable is more unmarked in (35b) than in (35a). Note further that in the same manner the second syl-



lable is also more unmarked in (35b) than in (35a). Hence, (35b) is every bit more unmarked than (35a). Now compare (35a) with (35b) as a whole. (35a) is composed of two syllable types CVC and VC, while (35b) is composed of such syllable types as CV and CVC. Following the assumption in (32), the number of unmarkedness would be given +3 to the former and -1 to the latter. Taken together, it can be concluded that rule ordering is not needed and that the Onset First Principle must be based on the structural unmarkedness assumed in this paper.

Given this, our discussion will go on to explore the VCV string. Note here that there can be two alternative ways of syllable division: V-CV and VC-V. Assuming (32), V-CV is assigned the value -3 and VC-V is assigned the value +1. It is thus V-CV instead of VC-V that is selected by the Onset First Principle. Similarly, given a string of the form VCCV, where CCV is a well-formed syllable, there would be three possible syllable divisions: V-CCV, VC-CV, and VCC-V. Even though the Onset First Principle will select V-CCV rather than the other two divisions, in no way can it pinpoint any difference between VC-CV and VCC-V. Following our assumption, however, it is possible to do it. Consider the following syllable structures.

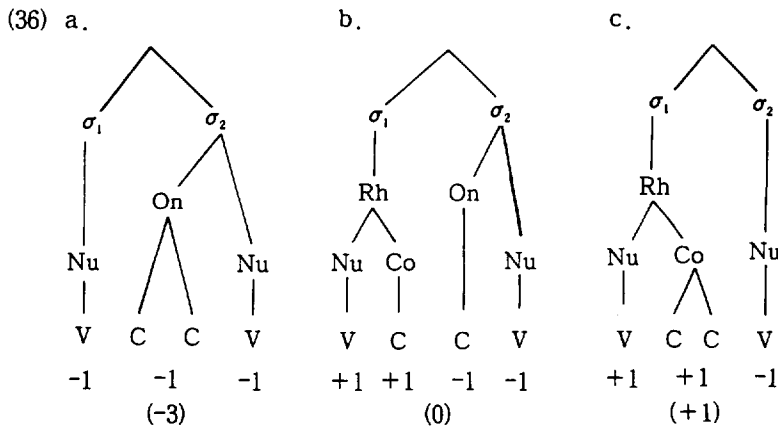

Since the three possible syllable divisions are represented as in (36) above, it may be possible to say that the degree of unmarkedness is determined in the order given. That is, (36a) is the most unmarked syllable division and the next is (36b), which is followed by (36c).

So far, we have shown that our assumption has an advantage over the Onset First Principle in that it makes it possible to dispense with the necessity of rule ordering in the

sense of Kahn and many others, and that it is much subtler than the First Onset Principle in determining the degree of unmarkedness as given in (36). Finally, let us return to (27), where we assumed that the higher the branching node is the more unmarked the syllable is. Given this assumption, it follows that (27a) is more unmarked than (27b), since the branching node in (27a) is the  $\sigma$  which is higher than the Rh where the branching in (27b) occurs. We have also pointed out that in a given string of the form VCV, the intervocalic C is not a Coda of the first syllable but an Onset of the second syllable, so that the syllable division is V-CV. The structural difference between the two cases is that when the intervocalic C is an Onset of the second syllable the branching occurs in the  $\sigma$ , which is higher than the Rh where the branching occurs when the intervocalic C is a Coda of the first syllable. Note further that this assumption should also be taken into account in order to understand the reality of the if-then condition on a sequence of three consonants in a syllable-initial position. Now consider the condition, which would be written as :

$$(37) \text{ If : } \begin{array}{ccc} \# \# & C_1 & C_2 & C_3 \\ & \Downarrow & \Downarrow & \Downarrow \\ & s & \left\{ \begin{array}{c} p \\ t \\ k \end{array} \right\} & \left\{ \begin{array}{c} r \\ l \\ y \\ w \end{array} \right\} \end{array}$$

Then :

That is, if a word begins with three C's in English, then the first consonant must be /s/, the second consonant must be /p,t,k/, and the third consonant must be /r,l,w,y/. But this if-then condition does not provide any explanation at all as to why it is so. (37) is purely formal and well described, but it is ad hoc. There are indeed no other cases in English in which a syllable begins with three consonants. But it is recently recognized that the first two consonants are not independent and that they should be treated as a single constituent in syllable Onset, as illustrated by their behavior in Old English alliterative poetry. Keeping this in mind, it follows that (37) can be replaced by the Onset structure of syllable, which would be represented as :

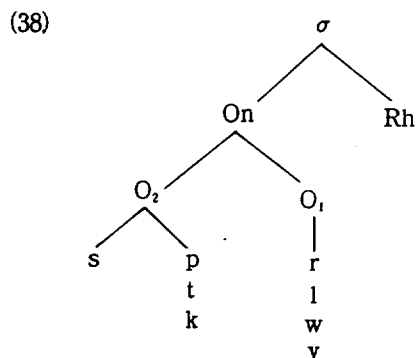

In (38), the first consonant /s/ and the second consonants /p,t,k/ are no longer independent, but act as a single unit, since they are all the members of one and the same terminal node  $O_2$ . Note that this view on the complex  $O_2$  has an advantage over the ternary structure of Onset represented by the if-then condition (37). Following the ternary branching of Onset, for instance, there would be no way of avoiding the difficulty with the SSG which is to meet a condition of descending value of sonority from the Peak. As a matter of fact, the if-then condition (37) is incompatible with the SSG, since the /p,t,k/, which are of the lowest sonority value, are preceded by the /s/, which is of higher sonority value than that of /p,t,k/. Now that (38) is given, however, there does not occur any violation of SSG, since there is no relation of precedence between the /s/ and the /p,t,k/, both of which are exhaustively dominated by a terminal node  $O_2$ .

Now compare the branching  $O_2$  of (38) with the non-branching  $O_2$ , the structure of which might be :

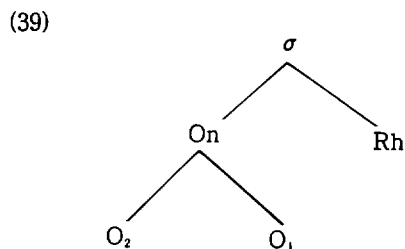

In the position of  $O_2$  in (38), there are only three possible cases : /sp/, /st/ and /sk/. To contrast, as remarked earlier, much more consonants — stops equivalent to (24a,b) and voiceless fricatives equivalent to (24c) — are to occupy the position of  $O_2$  in (39).

Given this phonotactic difference between (38) and (39) with regards to the position  $O_2$ , let us turn to the difference in unmarkedness between the two  $O_2$ 's. There are two branching nodes in (38) and only one branching node in (39) that are dominated by the topmost node  $\sigma$ . As mentioned earlier, any branching node that is dominated by the topmost node  $\sigma$  is the marked node. If we call such a node the Marked Branching Node [henceforth MBN] and the topmost node the Unmarked Branching Node [henceforth UBN] for the sake of our argument, then the difference between (38) and (39) with special reference to  $O_2$  is in the number of MBN: two MBN's in (38) and only one MBN in (39). Hence, it may be said that (38) is more marked than (39) and this results in the striking phonotactic difference between the two structures. Notice, however, that there would be no way of remarking on this type of difference if we follow the ternary branching structure of Onset, as in the case of (37), which might be structurally equivalent to (40) below.

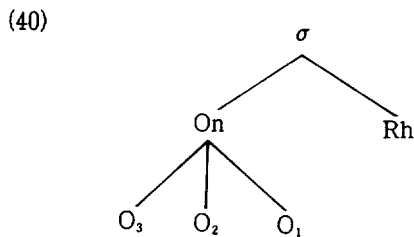

Two points are wrong with (40). For one thing, there occurs a violation of SSG between  $O_3$  and  $O_2$  in (40), as pointed out earlier. Secondly, (40) is to result in the same degree of unmarkedness as (39), since both are represented by only one MBN, in spite of the striking difference in unmarkedness. Taken together, our discussion thus far leads one to conclude that the degree of unmarkedness in the structure of Onset depends on the number of MBN: the more MBN the Onset segments have the more marked they are with regards to their phonotactic possibility. As a matter of fact, this conclusion is further supported by the observation that when there is no MBN there is practically no restriction on the consonants that can be placed on the position of Onset, to the exclusion of two phonemes in English such as /ŋ/ and /z/.

Turning back to (38), note that not all the three possible consonant clusters in  $O_2$  can phonotactically be combined with four phonemes in  $O_1$ . There can not be /spw/, /stl/ and /stw/ in English word-initial position. To put it another way, the English word-initial /sk/

can be combined with four phonemes all in  $O_1$ , while the /sp/ can be combined with three phonemes but /w/ and the /st/ with only two phonemes but the /l/ and /w/ in  $O_1$ . Such being the case, it is possible to say that with regards to the phonotactic permissibility there is a degree of unmarkedness to the extent that the /sk/ is least marked, the /sp/ is in-between and the /st/ is most marked. It is worth noting here that the difference in the degree of unmarkedness we observed is clearly reflected by the CP analysis presented in the previous section. Consider the following CP analysis.

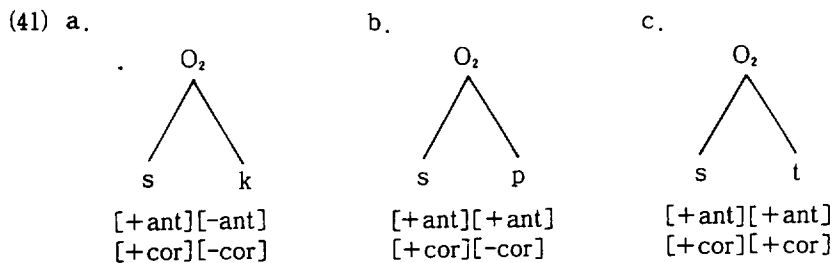

As can be seen here, there are two CP's, [ant] and [cot] in (41a), while only one CP, [cor] in (41b) and no CP in (41c). Hence, the degree of unmarkedness decreases in the order given in (41).

Up to this point, we have chiefly focused on the discussion of the Onset structure, with special reference to the criticism against the if-then condition on a string of three consonants in the word-initial position. In what follows, therefore, it will be shown that what we have observed with regards to the Onset structure can also be true of the Nucleus and Coda. Now consider the following structures.

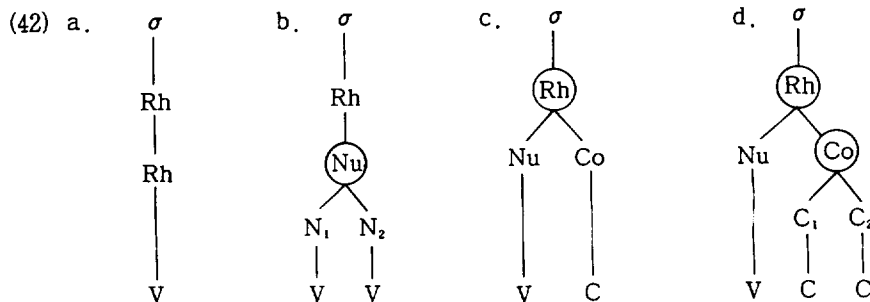

Note that by the preceding definition, the circled nodes in (42) are MBN's. The structural contrast between (42a) and (42b) is that the former is of no MBN and the latter is

of one MBN. Following the assumption made in our discussion of the Onset structure, it may also be said that (42b) is more marked than (42a). Exactly the same holds true of the comparison between (42c) and (42d). That is, (42d) is more marked than (42c), since the latter is characterized by two MBN's as opposed to the former characterized by one MBN. Given this, it follows that the degree of unmarkedness is determined by the number of MBN's that can be placed between the UBN and the terminal string of segments in the syllable structure. One thing to be further noted here is that (42c) is less marked than (42b), though they are all characterized by one MBN. This is because the MBN in (42c) is the Rh, which is in a higher level than the Nu in (42b). In passing, remember here that in the previous section we assumed that marked segments imply unmarked segments: for instance, the /b, d, g/ imply the /p, t, k/. In addition, the fact that marked segments can be neutralized as unmarked counterpart in a certain context made it possible to assume that the relative markedness plays a role in determining the direction of sound change. It is indeed a well-known fact that marked segments are likely to be changed into unmarked segments. For the same reason, it can also be assumed that in a syllable structure the marked structure is likely to be changed into the unmarked one. Since the degree of unmarkedness in a syllable structure is determined by the number of MBN's and the level of MBN, it will be possible to say that phonological changes occur in a direction of both reducing the number of MBN's and raising the level of MBN. Let us take a few examples for this. Notice first that the sequence /iu/ is devoiced into /yu/ rather than into /iw/. This is because when turning /i/ into /y/ results in a more unmarked syllable structure than when turning /u/ into /w/. More specifically, turning /i/ into /y/ gives rise to the most unmarked type of syllable structure with no MBN. Turning /u/ into /w/, however, gives rise to the still somewhat marked type of syllable structure with the MBN in the level of Rh. For the sake of precision, consider the following.

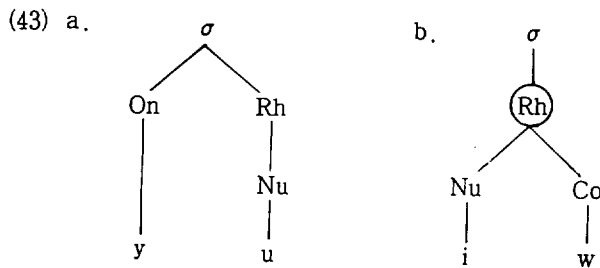

As has been noted above, the circled node in (43) indicates the MBN. Such being the

case, the devocalization of /iu/ into /yu/ is simply accounted for. Secondly, as pointed out by Hyman (1975: 18), a syllable consisting of a string of CVC is more likely to become CV than VC. For instance, the spelling of the French word *rat* 'rat' indicates that there once was a final /t/. The original /rat/ has become /ra/, and not /at/. A similar example is taken from the Proto-Bamileke form /kam/ 'crab', which has become /ka/ in Dschang-Bamileke, and not /am/. The two examples show that phonological changes take place in the direction of unmarkedness rather than of markedness. As a matter of fact, deleting the consonant dominated by the node Coda has the effect of reducing the MBN in the level of Rh, while deleting the consonant dominated by the node Onset can not have any effect of reducing the MBN, but it rather makes the structure worse by destroying the function of UBN. The final example is taken from the pronunciation of the word *ice cream* by my two children. The word was pronounced /ha-kim/ by my six-year old child at her age of two or three and /aɲ-kim/ by my two-year old child. Since the second syllable /kim/ has been mentioned in the previous discussion, our focus will be placed on the discussion of the first syllable. Despite the difference in their actual pronunciation of the word *ice*, what they have in common is the change into the unmarked structure from the marked structure of the syllable. Note indeed that the /ais/ is extremely marked with two MBN's, Nu and Rh. The /ha/ results from reducing both MBN's, though /h/ is inserted into the position of Onset. The /aɲ/, on the other hand, results from reducing one MBN in the level of Nu, though the /s/ is replaced by the /ɲ/ in the position of Coda.

#### IV. Conclusion

To summarize, we have pointed out that in many cases of phonological phenomena the formal approach does not go beyond a stage of description of some body of data. As an example of this can the if-then condition (2) be given, in terms of which the English word-initial consonant clusters \*/pw/ and \*/bw/ are not permissible, while /tw/, /dw/, /kw/ and /gw/ are permissible. But the condition does not give any account of why it is so. In this paper, however, we have demonstrated that some parameters of contrast play a pivotal role in accounting for the essence of the if-then condition. Following our approach in section II, for example, the \*/pw/ and \*/bw/ are impermissible, since there is no CP between the two segments in question. One of the advantages of our approach

over the formal approach is the fact that our approach even makes it possible to determine the degree of unmarkedness for the above four permissible clusters. In section III, we have also pointed out that in the hierarchically internal structure of syllable, the degree of unmarkedness is determined by the number and the level of the branching nodes.



## References

- Clements, G. N. & S. J. Keyser (1983) *CV Phonology*. Cambridge : MIT Press.
- Hogg, H. & C. B. McCully (1987) *Metrical Phonology: A coursebook*. Cambridge : Cambridge University Press.
- Hooper, J. B. (1976) *An Introduction to Natural Generative Phonology*, New York : Academic Press.
- Hyman, L. (1975) *Phonology: Theory and analysis*. New York : Holt, Rinehart & Winston.
- Jones, D. (1957) *An Outline of English Phonetics*. Cambridge : W. Heffer & Sons.
- Kahn, D. (1976) *Syllable-based Generalizations in English Phonology*. Bloomington : Indiana University Linguistics Club.
- Kim, C. W. (1982) "The rise and rite of non-linear phonology." In *Selected Papers from SICOL-1981*, eds. 1982. Seoul : Hanshin Publishing Co. 93-110.
- Lass, R. (1984) *Phonology*. Cambridge : Cambridge University Press.
- Ladefoged, P. (1982) *A Course in Phonetics*. New York : Harcourt Brace Jovanovich.
- Ohala, J. J. & J. Kawasaki (1984) "Prosodic Phonology and Phonetics." In Ewen, C. & J. Anderson, eds. 1984. *Phonology Yearbook 1*. Cambridge Univesity Press. 113-127.
- Ross, J. R. (1966d) "A proposed rule of tree-pruning." In Reibel, D. & S. Schane, eds. 1969. *Modern Studies in English*. Prentice-Hall. k288-299.
- Schane, S. A. (1973) *Generative Phonology*. Englewod Cliffs, N.J. : Prentice-Hall.
- Selkirk, E. O. (1982) "The Syllable." In van der Hulst & Smith. 1982. Part II. 337-383.
- (1984a) "On the major class features and syllable theory." In Aronoff M. & R. T. Oehrle, eds. 1984. *Language Sound Structure*. Cambridge : MIT Press. 107-136.
- Sloat, C. et al. (1978) *Introduction to Phonology*. N.J. : Prentice-Hall.

<국문초록>

## 음운론적 무표지성의 매개변수

이 기 석

이 논문에서는 영어의 if-then Condition과 같은 지극히 형식적인 조건이나 규칙이 음운론적인 현상을 정확하게 기술할 수는 있을 지언정 결코 설명적이 되지 않는다는 사실을 지적하고, 이와 같은 현상에 대한 설명이 무표지성의 매개 변수로써 가능함을 보이고자 했다. 예를 들어 영어에서 /pw/와 /bw/는 단어초의 자음군으로서 불가능하지만, /tw/, /dw/, /kw/, /gw/는 가능하다. If-then Condition으로 이 사실을 간단히 나타낼 수 있지만, 이 사실 뿐만 아니라 더 자세히 분석해 보면 [ant], [vd], [cor] 등의 매개변수를 동원해서 /tw/, /dw/, /kw/, /gw/ 사이에서도 가능할 수 있는 정도의 차이, 즉 무표지성에 있어서의 정도차이가 있음을 지적했다. 아울러서 이 순서대로 영어의 단어초 자음군의 어휘빈도수가 결정되고 있음도 발견했다. 다른 한편으로는 음절 구조에 있어서도 분지하는 마디의 수와 분지하는 마디의 계층에 따라서 음절의 무표지성이 결정되고 있음을 밝혀낸바, 분지하는 마디수가 많을수록 무표지성은 감소하고 분지하는 마디의 계층이 상위에 있을수록 무표지성은 증가한다. 예를 들어 Clements & Keyser가 말하는 네 가지 유형의 핵심음절이 CV, V, CVC, VC 인데, 여기서 CV가 가장 무표적이고 차례대로 무표지성이 감소하여 VC가 가장 유효적이다. 이 사실이 음절 구조의 나무 그림을 통하여 극명하게 입증되었다.